

2 way, 2 position solenoid valve, poppet type (normally open)

SV3-12.-0-0-.....

MS-440-119-00

(subject to change)

FAT•N

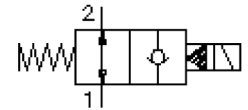

HEX 3/4"
(torque
cartridge:
5 - 8 Nm)

HEX 1 1/4"
(torque
cartridge:
85 - 94 Nm)

cavity:
C-12-2
see
data-sheet no.:
IK-100-129-00

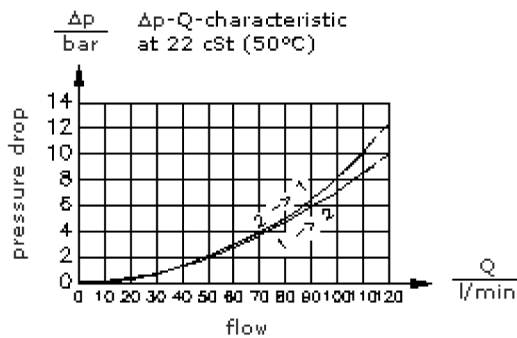
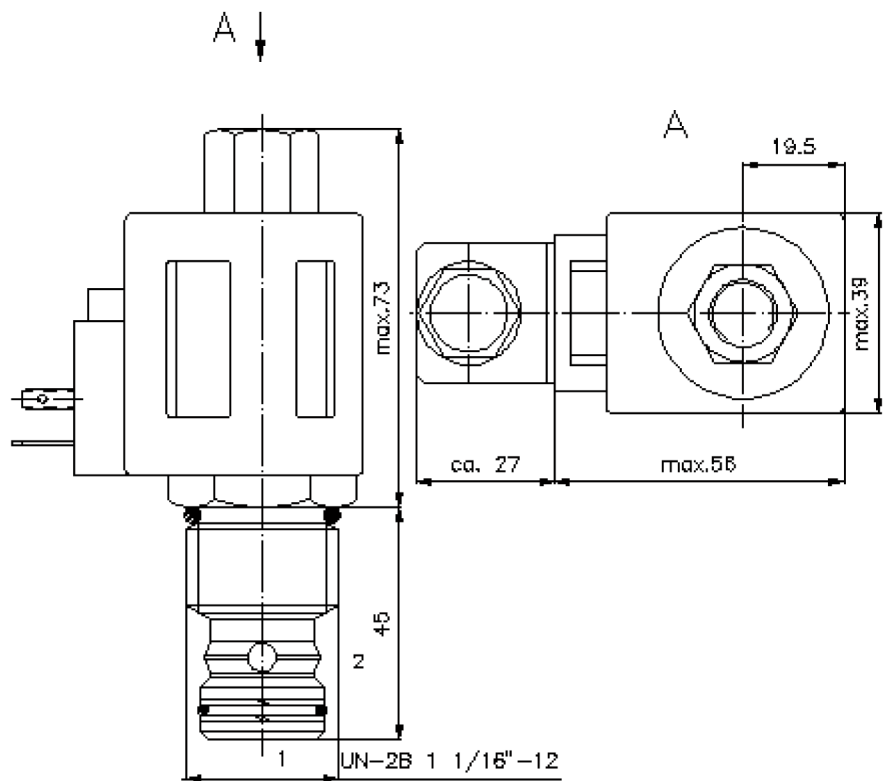

2 way, 2 position solenoid valve, poppet type (normally open)

SV3-12.-0-0-.....

Motrac Hydraulik GmbH
Siemensring 87 - D-47877 Willich
fon +49-(0)2154-8162.0 - fax +49-(0)2154-8162.499
e-mail info.mhw@motracindustries.com
internet www.motracindustries.com

FAT•N

MS-440-119-00

(subject to change)

Ordering example:

SV3 - 12N - 0 - 0 - 024D - G

A
 B
 C
 D
 E
 F

Model code:

- | | |
|--|--|
| <p>A design
solenoid valve
poppet type valve
pilot operated</p> <p>B size and sealing
12N = Buna (NBR)
12V = Viton (FPM)</p> <p>C symbol function mode
0 = normally open</p> <p>D construction
0 = screw-in valve</p> <p>E voltage
DC current:
012D = 12V DC
024D = 24V DC
AC current:
120A = 120V AC
240A = 240V AC
other voltage on request</p> | <p>F power supply
G = DIN 43650 connector, other
connectors see data sheet no.: MS-010-000-00</p> |
|--|--|

Technical Data:

nominal pressure:	210 bar
nominal flow:	114 l/min
weight:	0.4 kg
temperature range:	-40°C to 120°C
fluids:	hydraulic oil as per DIN 51524 T1 (ISO TC 131)
max. leakage:	5 drops/min at 22 cSt (50°C) and 210 bar
seals:	optional Buna (NBR) or Viton (FPM), as well as Teflon wascher (PTFE)
power consumption:	20 W
response times:	with 100% change of current, nominal pressure and approx. 80% of the flow open: 75 ms close: 150 ms
cavity:	C-12-2 see datasheet no. IK-100-129-00
housing:	2LH-12.-B.. see datasheet no. IH-100-000-00
seal kit:	SP-MDS-12N-22 (NBR), SP-MDS-12V-22 (FPM)