

# 2 way, 2 position solenoid valve, poppet type (normally closed)

SBV11-10.-C-0-.....H

MS-260-101-00

(subject to change)

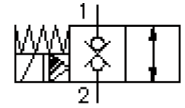

HEX 3/4"  
(torque  
cartridge:  
5 - 8 Nm)

HEX 1"  
(torque  
cartridge:  
48 - 54 Nm)

cavity:  
C-10-2  
see  
data-sheet no.:  
IK-100-109-00

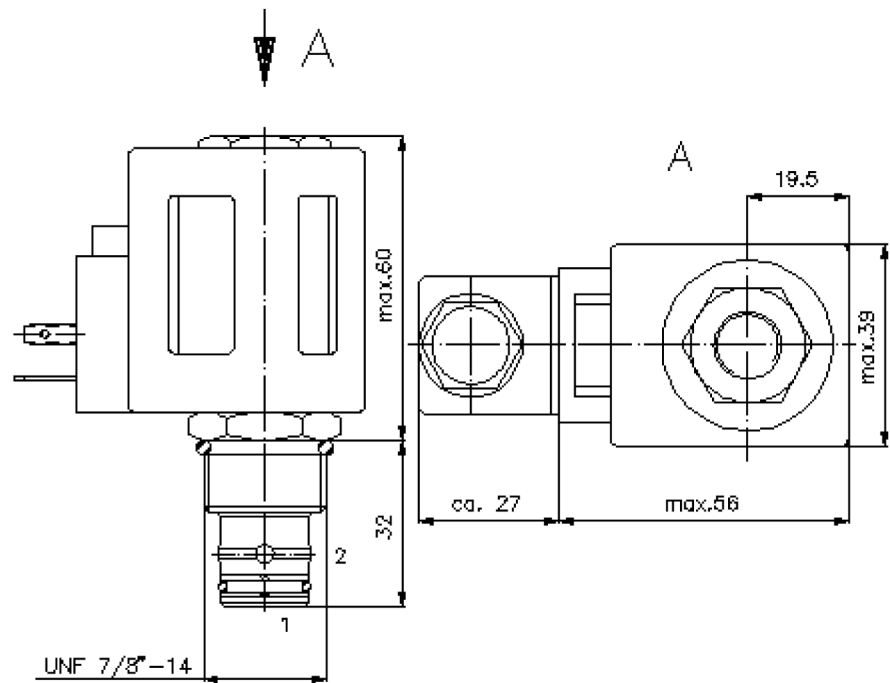

$\frac{\Delta p}{\text{bar}}$   $\Delta p$ -Q-characteristic  
at 22 cSt (50°C)

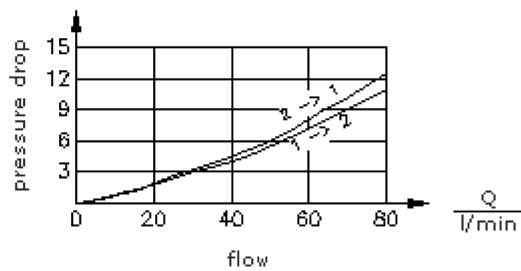

# 2 way, 2 position solenoid valve, poppet type (normally closed)

SBV11-10.-C-0-.....H

Motrac Hydraulik GmbH  
Siemensring 87 - D-47877 Willich  
fon +49-(0)2154-8162.0 - fax +49-(0)2154-8162.499  
e-mail info.mhw@motracindustries.com  
internet www.motracindustries.com

**FAT•N**

**MS-260-101-00**

(subject to change)

## Ordering example:

SBV11 - 10N - C - 0 - 024D - G H

A   
 B   
 C   
 D   
 E   
 F   
 G

## Model code:

- |  |  |
|--|--|
| <p><b>A design</b><br/>solenoid valve<br/>double poppet valve<br/>pilot operated</p> <p><b>B size and sealing</b><br/>10N = Buna (NBR)<br/>10V = Viton (FPM)</p> <p><b>C symbol function mode</b><br/>C = normally closed</p> <p><b>D construction</b><br/>0 = screw-in valve</p> <p><b>E voltage</b><br/>DC current:<br/>012D = 12V DC<br/>024D = 24V DC<br/>AC current:<br/>120A = 120V AC<br/>240A = 240V AC<br/>other voltage on request</p> | <p><b>F power supply</b><br/>G = DIN 43650 connector, other<br/>connectors see data sheet no.: MS-010-<br/>000-00</p> <p><b>G coil</b><br/>H = high pressure variant</p> |
|--|--|

## Technical Data:

<b>nominal pressure:</b>	350 bar
<b>nominal flow:</b>	76 l/min
<b>weight:</b>	0.4 kg
<b>temperature range:</b>	-40°C to 100°C
<b>fluids:</b>	hydraulic oil as per DIN 51524 T1 (ISO TC 131)
<b>max. leakage:</b>	5 drops/min at 22 cSt (50°C) and 350 bar
<b>seals:</b>	optional Buna (NBR) or Viton (FPM), as well as Teflon wascher (PTFE)
<b>power consumption:</b>	26 W
<b>cavity:</b>	C-10-2 see datasheet no. <a href="#">IK-100-109-00</a>
<b>housing:</b>	2LH-10.-B.. see datasheet no. <a href="#">IH-100-000-00</a>
<b>seal kit:</b>	SP-MDS-10N-22 (NBR), SP-MDS-10V-22 (FPM)