

pressure sequence screw-in valve (direct acting, adjustable)

PSV4-08.-.-0-..

MP-510-081-00

(subject to change)

FAT-N

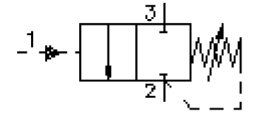

HEX 1/2"

HEX 7/8"
(torque
cartridge:
34 - 40 Nm)

cavity:
C-08-3
see
data-sheet no.:
[IK-300-089-00](#)

HEX 4 mm

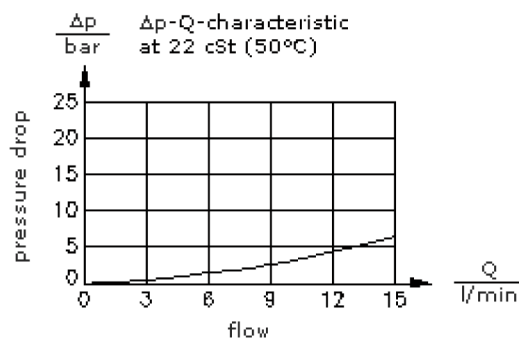
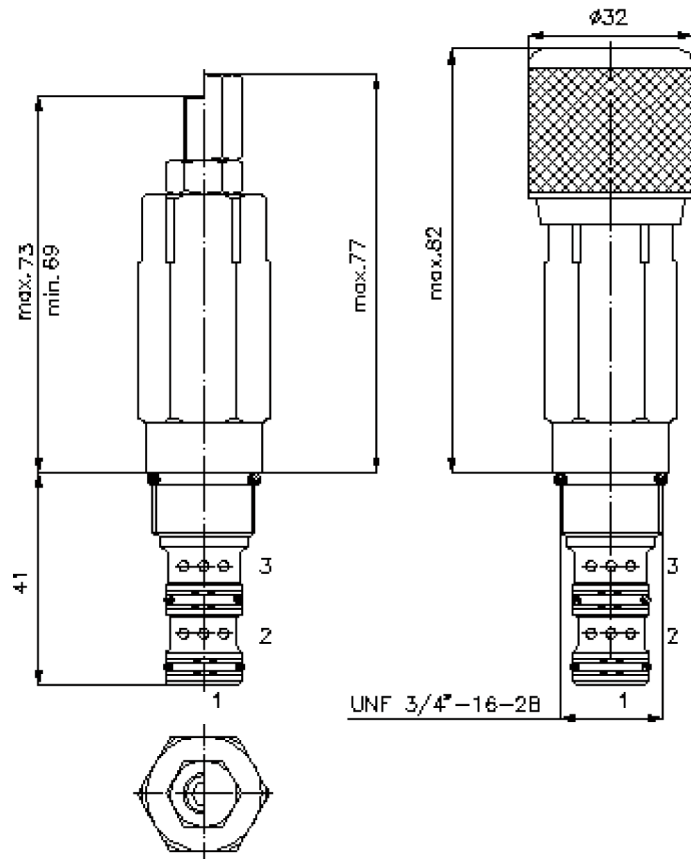

pressure sequence screw-in valve (direct acting, adjustable)

PSV4-08.-.-0-..



Motrac Hydraulik GmbH
Siemensring 87 - D-47877 Willich
fon +49-(0)2154-8162.0 - fax +49-(0)2154-8162.499
e-mail info.miw@motracindustries.com
internet www.motracindustries.com

FAT•N

MP-510-081-00

(subject to change)

Ordering example:

PSV4 - 08N - C - 0 - 30
| | | | |
A **B** **C** **D** **E**

Model code:

A design
pressure-sequence-valve
spool type valve
direct acting

B size and sealing
08N = Buna (NBR)
08V = Viton (FPM)

C adjustment
S = screw adjustment
C = cap
K = handknob

D construction
0 = screw-in valve

E pressure range
15 = 28.0 - 100 bar
30 = 3.4 - 210 bar
50 = 124.0 - 350 bar

Technical Data:

nominal pressure:	350 bar
nominal flow:	15 l/min
weight:	0.21 kg
temperature range:	-40°C to 120°C
fluids:	hydraulic oil as per DIN 51524 T1 (ISO TC 131)
max. leakage:	85 ccm/min. at 22 cSt (50°C) and 210 bar
seals:	optional Buna (NBR) or Viton (FPM), as well as Teflon wascher (PTFE)
cavity:	C-08-3 see datasheet no. IK-300-089-00
housing:	3LH-08.-B.. see datasheet no. IH-300-000-00
seal kit:	SP-MDS-08N-34 (NBR), SP-MDS-08V-34 (FPM)