

# 3-way pressure compensator screw-in valve

PCS4-10.-0-...



**MF-650-100-00**

(subject to change)

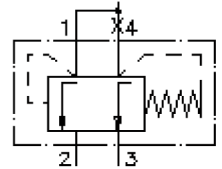

HEX 1"  
(torque  
cartridge:  
48 - 54 Nm)

cavity: C-10-4  
see  
data-sheet no.:  
IK-400-109-00

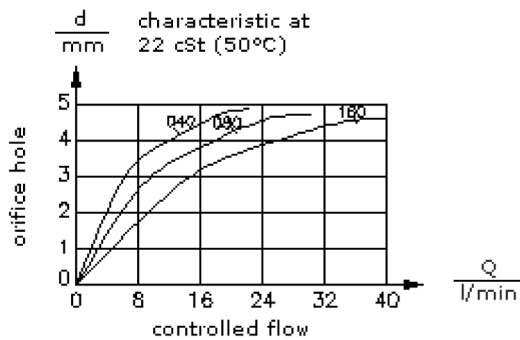
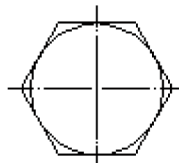
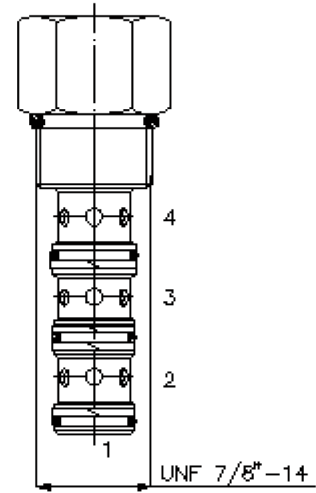
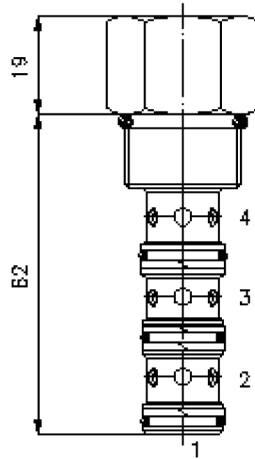

# 3-way pressure compensator screw-in valve

PCS4-10.-0-...



Motrac Hydraulik GmbH  
Siemensring 87 - D-47877 Willich  
fon +49-(0)2154-8162.0 - fax +49-(0)2154-8162.499  
e-mail info.miw@motracindustries.com  
internet www.motracindustries.com

MF-650-100-00

(subject to change)

FAT•N

## Ordering example:

PCS4 - 10N - 0 - 040  
|        |        |        |  
**A**    **B**    **C**    **D**

## Model code:

**A** **design**  
pressure compensator

**B** **size and sealing**  
10N = Buna (NBR)  
10V = Viton (FPM)

**C** **construction**  
0 = screw-in valve

**D** **differential pressure**  
040 = 2.8 bar  
080 = 5.5 bar  
160 = 11.0 bar

## Technical Data:

**nominal pressure:** 210 bar  
**nominal flow:** 38 l/min  
**weight:** 0.14 kg  
**temperature range:** -40°C to 120°C  
**fluids:** hydraulic oil as per DIN 51524 T1 (ISO TC 131)  
**seals:** optional Buna (NBR) or Viton (FPM), as well as Teflon wascher (PTFE)  
**cavity:** C-10-4 see datasheet no. [IK-400-109-00](#) Review note!  
**housing:** 4LH-10.-B.. see datasheet no. [IH-400-000-00](#)  
**seal kit:** SP-MDS-10N-44 (NBR), SP-MDS-10V-44 (FPM)