

2 way, 2 position logic poppet valve type "B"

DPS2-20.-B-.-0-...-..

MD-710-201-00

(subject to change)

FAT•N

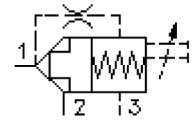

HEX 1 7/8"
(torque
cartridge:
129 - 155 Nm)

cavity:
C-20-3S
see
data-sheet no.:
[IK-200-209-00](#)

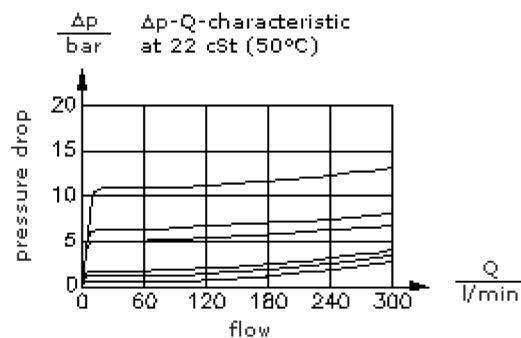
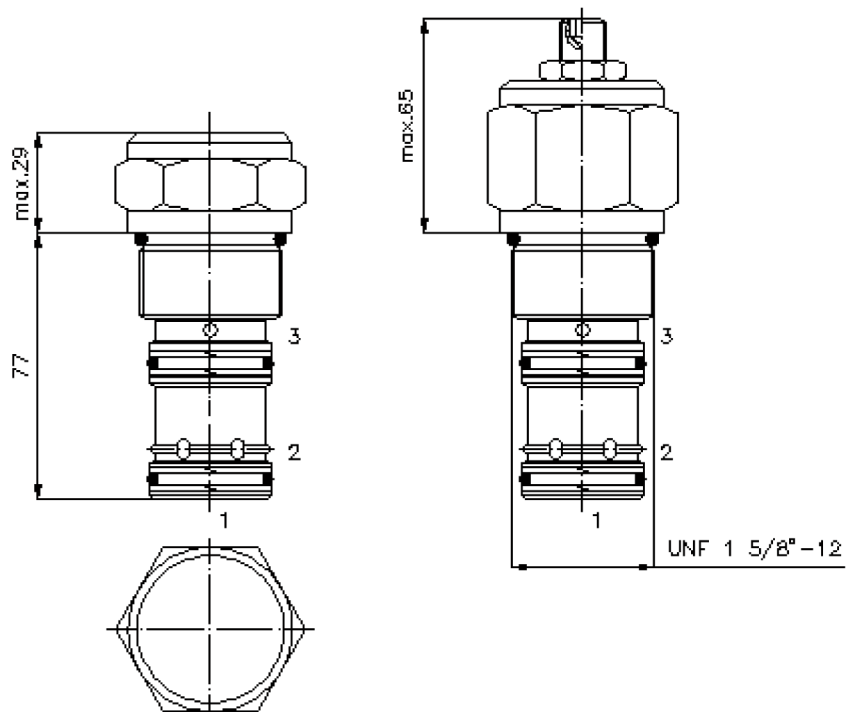

2 way, 2 position logic poppet valve type "B"

DPS2-20.-B-.-0-....-

MD-710-201-00

(subject to change)

FAT•N

Ordering example:

DPS2 - 20N - B - F - 0 - 040 - AA
| | | | | | |
A **B** **C** **D** **E** **F** **G**

Model code:

- | | |
|---|--|
| A design
logic valve | E construction
0 = screw-in valve |
| B size and sealing
20N = Buna (NBR)
20V = Viton (FPM) | F crack pressure
040 = 2.8 bar
080 = 5.5 bar
160 = 11.0 bar |
| C spool type
B = release to open
base position closed | G function mode
00 = 210 bar variant
AA = 350 bar variant |
| D adjustment
F = fixed
S = stroke limiter | |

Technical Data:

nominal pressure:	350 bar
nominal flow:	303 l/min
weight:	0.81 kg
temperature range:	-40°C to 120°C
fluids:	hydraulic oil as per DIN 51524 T1 (ISO TC 131)
max. leakage:	1 -> 2 = 5 drops/min at 22 cSt (50°) and 350 bar
seals:	optional Buna (NBR) or Viton (FPM), as well as Teflon wascher (PTFE)
pilot ratio:	2 : 1
cavity:	C-20-3S see datasheet no. IK-200-209-00
housing:	3SLH-20.-B.. see datasheet no. IH-200-000-00
seal kit:	SP-MDS-20N-34S (NBR), SP-MDS-20V-34S (FPM)