

3 way, 3 position hot oil shuttle valve relieved center-position

DSV4-10.-0-0-...

MD-450-101-00

(subject to change)

FAT•N

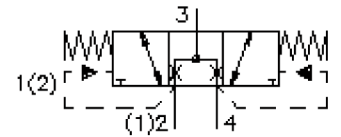

HEX 1"
(torque
cartridge:
48 - 54 Nm)

cavity: C-10-4
see
data-sheet no.:
IK-400-109-00

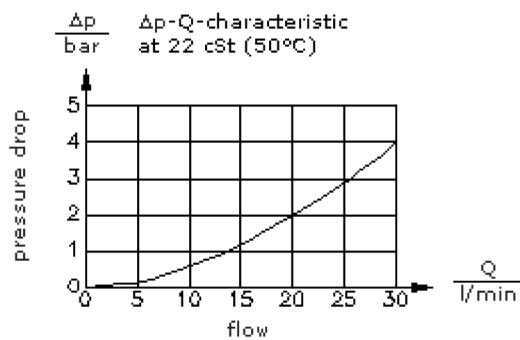
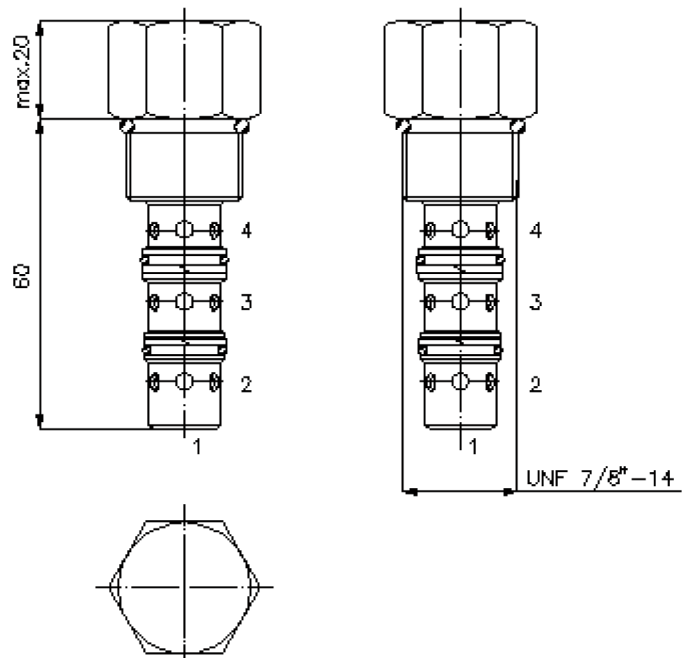

3 way, 3 position hot oil shuttle valve relieved center-position

DSV4-10.-0-0-...



Motrac Hydraulik GmbH
Siemensring 87 - D-47877 Willich
fon +49-(0)2154-8162.0 - fax +49-(0)2154-8162.499
e-mail info.mhw@motracindustries.com
internet www.motracindustries.com

FAT•N

MD-450-101-00

(subject to change)

Ordering example:

DSV4 - 10N - 0 - 0 - 040
| | | | |
A **B** **C** **D** **E**

Model code:

- | | |
|---|--|
| A design
hot oil shuttle valve | D construction
0 = screw-in valve |
| B size and sealing
10N = Buna (NBR)
10V = Viton (FPM) | E switching pressure
040 = 2.8 bar
080 = 5.5 bar
160 = 11.0 bar |
| C spool type
0 = center position open | |

Technical Data:

nominal pressure:	350 bar
nominal flow:	26 l/min
weight:	0.14 kg
temperature range:	-40°C to 120°C
fluids:	hydraulic oil as per DIN 51524 T1 (ISO TC 131)
max. leakage:	165 ccm/min at 22 cSt (50°C) and 210 bar
seals:	optional Buna (NBR) or Viton (FPM), as well as Teflon wascher (PTFE)
cavity:	C-10-4 see datasheet no. IK-400-109-00 Review note!
housing:	4LH-10.-B.. see datasheet no. IH-400-000-00
seal kit:	SP-MDS-10N-32 (NBR), SP-MDS-10V-32 (FPM)