

# counterbalance valve, screw-in type (adjustable)

CBV.-10.-.-0-.-..

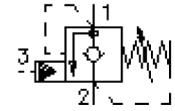

HEX 1/2"

HEX 1"  
(torque  
cartridge:  
48 - 54 Nm)

cavity:  
C-10-3S  
see  
data-sheet no.:  
[IK-200-109-00](#)

HEX 4 mm

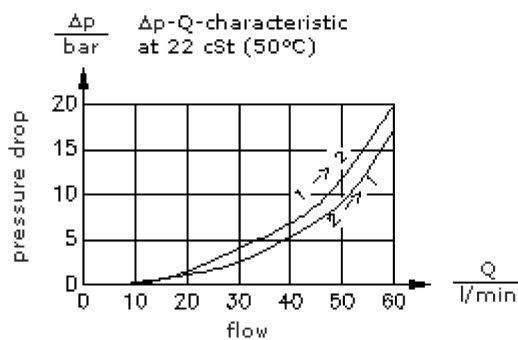
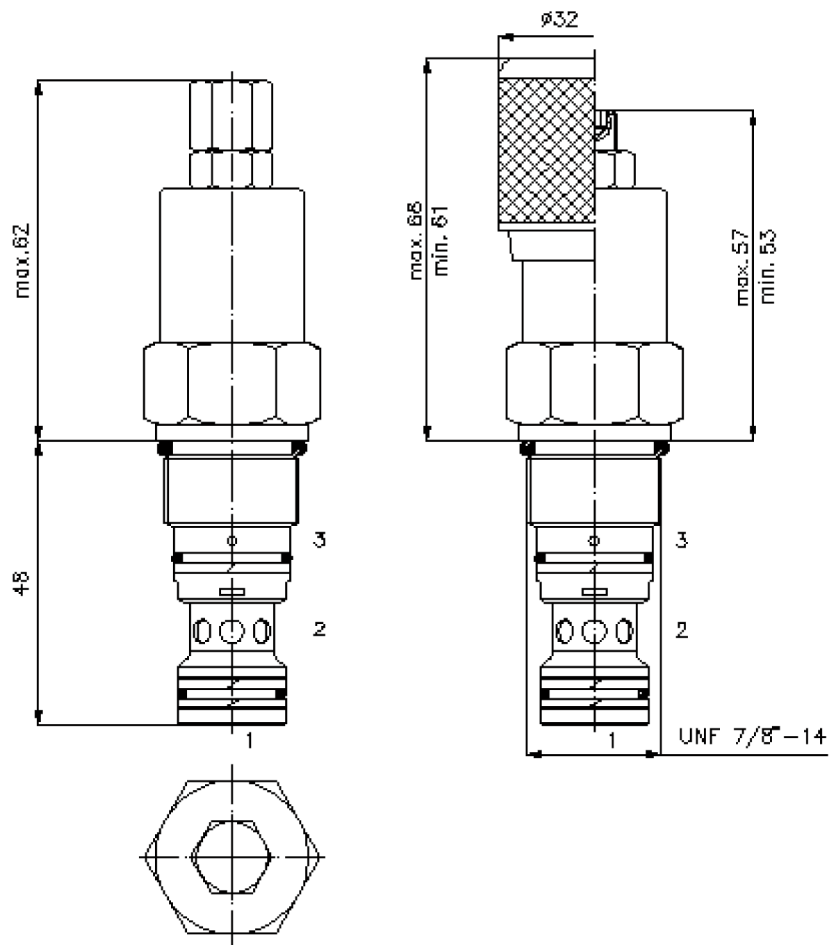

# counterbalance valve, screw-in type (adjustable)

CBV.-10.-.-0-.-..



Motrac Hydraulik GmbH  
Siemensring 87 - D-47877 Willich  
fon +49-(0)2154-8162.0 - fax +49-(0)2154-8162.499  
e-mail info.miw@motracindustries.com  
internet www.motracindustries.com

FAT•N

MC-410-101-00

(subject to change)

## Ordering example:

CBV    1   - 10N -   C   -   0   -   A   -   50  
|        |        |        |        |        |  
**A**    **B**    **C**    **D**    **E**    **F**    **G**

## Model code:

**A** **design**  
counter balance valve

**B** **pilot ratio**  
1 = 4 : 1  
2 = 10 : 1

**C** **size and sealing**  
10N = Buna (NBR)  
10V = Viton (FPM)

**D** **adjustment**  
S = screw adjustment  
C = cap  
K = handknob

**E** **construction**  
0 = screw-in valve

**F** **check valve free flow crack pressure**  
A = 1.4 bar  
B = 0.28 bar

**G** **pressure range**  
30 = 62.0 - 210 bar  
50 = 186.0 - 350 bar

## Technical Data:

<b>note:</b>	left turn (counter clockwise) = increasing pressure right turn (clockwise) = reducing pressure
<b>nominal pressure:</b>	350 bar
<b>nominal flow:</b>	60 l/min
<b>weight:</b>	0.23 kg
<b>temperature range:</b>	-40°C to 120°C
<b>fluids:</b>	hydraulic oil as per DIN 51524 T1 (ISO TC 131)
<b>max. leakage:</b>	5 drops/min at 22 cSt (50°C) and 77% crack pressure
<b>seals:</b>	optional Buna (NBR) or Viton (FPM), as well as Teflon wascher (PTFE)
<b>cavity:</b>	C-10-3S see datasheet no. <a href="#">IK-200-109-00</a>
<b>housing:</b>	3SLH-10.-B.. see datasheet no. <a href="#">IH-200-000-00</a>
<b>seal kit:</b>	SP-MDS-10N-33S (NBR), SP-MDS-10V-33S (FPM)