

# linking/crossover plate CETOP 7 (P with T connected, A, B, X, Y and L closed)

UP-16.-PT



Motrac Hydraulik GmbH  
Siemensring 87 - D-47877 Willich  
fon +49-(0)2154-8162.0 - fax +49-(0)2154-8162.499  
e-mail info.miw@motracindustries.com  
internet www.motracindustries.com

IZ-850-501-00

(subject to change)

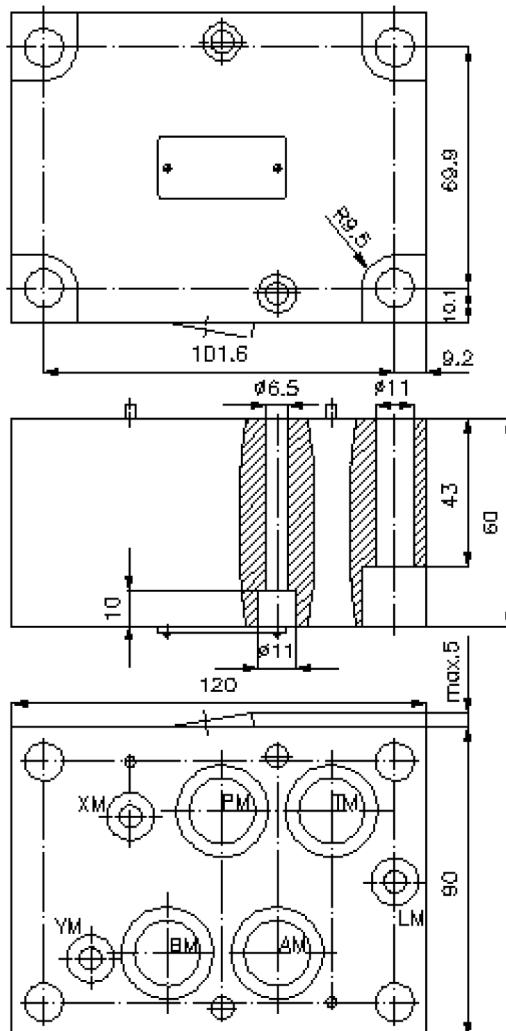
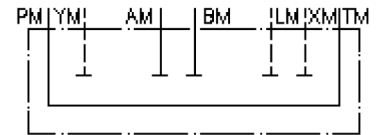

# linking/crossover plate CETOP 7 (P with T connected, A, B, X, Y and L closed)

UP-16.-PT



Motrac Hydraulik GmbH  
Siemensring 87 - D-47877 Willich  
fon +49-(0)2154-8162.0 - fax +49-(0)2154-8162.499  
e-mail info.miw@motracindustries.com  
internet www.motracindustries.com

IZ-850-501-00

(subject to change)

## Ordering example:

UP   - 16A - PT  
|        |        |  
**A**    **B**    **C**

## Model code:

- A design**  
turn round plate  
with mounting interface DIN 24340 form A
- B size and material**  
16A = aluminum (F37)  
16S = steel (9SMnPb28K resp. GGG-40)
- C function mode**  
PT = P with T connected

## Technical Data:

- note:** required mounting screws:  
2 pcs. M6 x 60 DIN 912  
4 pcs. M10 x 60 DIN 912
- nominal pressure:** 250 bar (A)  
350 bar (S)
- weight:** 1.8 / 5.5 kg (A/S)