

check valve plate CETOP 3 ((sandwich plate) in P with port in D)

RMZ-06S-PD

IZ-120-200-00

(subject to change)

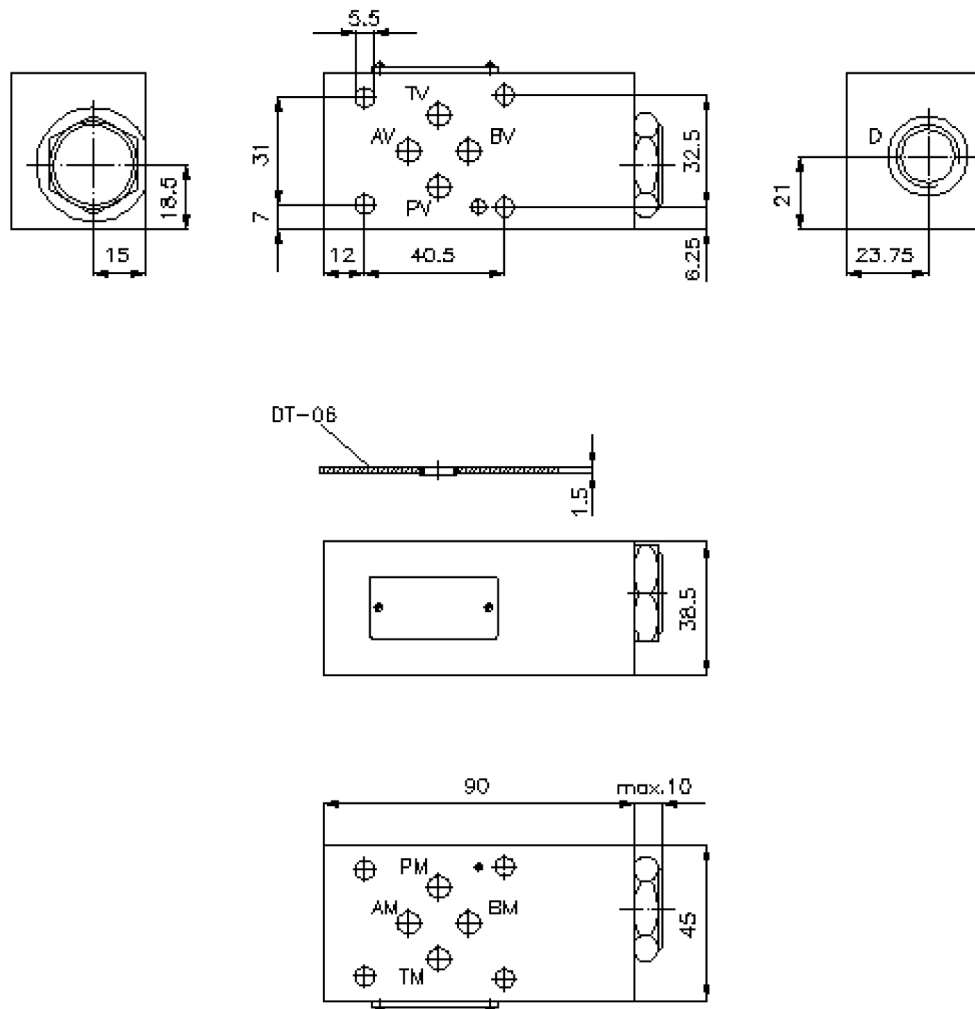
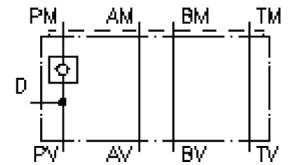

check valve plate CETOP 3 ((sandwich plate) in P with port in D)

RMZ-06S-PD

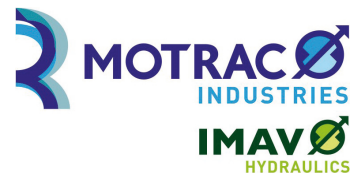

Motrac Hydraulik GmbH
Siemensring 87 - D-47877 Willich
fon +49-(0)2154-8162.0 - fax +49-(0)2154-8162.499
e-mail info.miw@motracindustries.com
internet www.motracindustries.com

IZ-120-200-00

(subject to change)



Ordering example:

RMZ - 06S - PD
| | |
A **B** **C**

Model code:

- | | |
|---|---|
| A design
check valve plate
with mounting interface DIN 24340 form A
sandwichplate design | B size and material
06S = steel (9SMnPb28K resp. GGG-40) |
| | C function mode
PD = check valve in the "P" channel with
accumulator port |

Technical Data:

nominal pressure:	350 bar
nominal flow:	60 l/min
weight:	1.3 kg
crack pressure:	approx. 0.7 bar (standard), other pressure on request
free flow direction:	see symbol
check valve:	CV3-10.-... see datasheet no. <u>MC-130-100-00</u>
included:	DT-06 = sealing plate with vulcanized O-ring (Viton FPM)