

# pressure relief valve, screw-in type (with by-pass check valve)

RVPP-10.-.-0-..

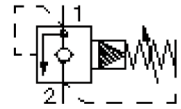

SW 19 mm

SW 27 mm  
(Anzugs-  
Drehmoment:  
48 - 54 Nm)

Aufnahme-  
bohrung  
C-10-2  
siehe  
Massblatt-Nr.:  
IK-100-109-00

SW 8 mm

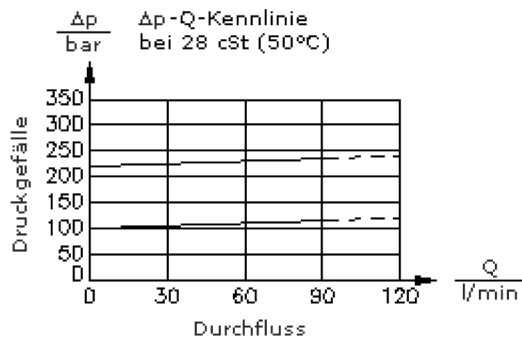
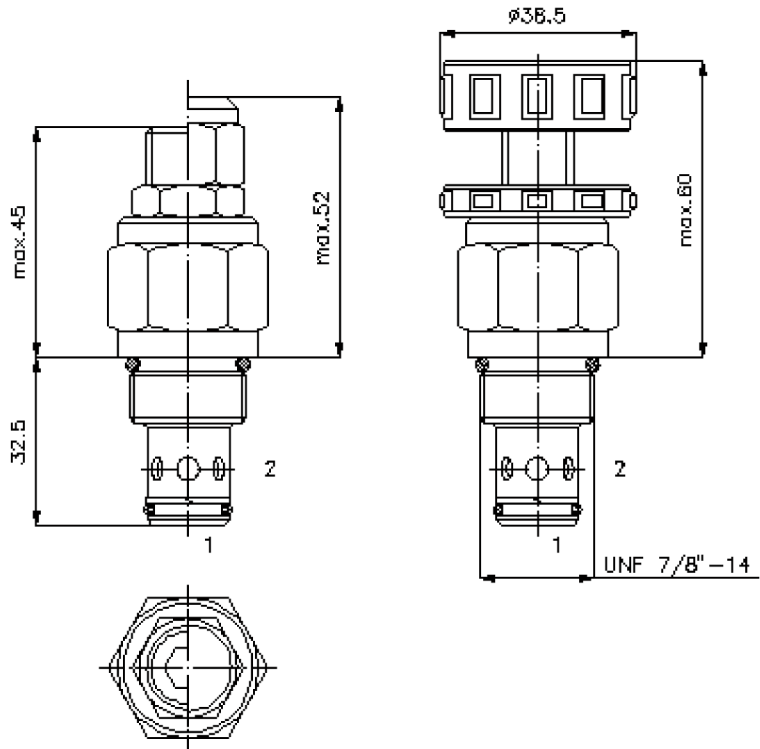

# pressure relief valve, screw-in type (with by-pass check valve)

RVPP-10.-.-0-..

**BUCHER**  
hydraulics



Motrac Hydraulik GmbH  
Siemensring 87 - D-47877 Willich  
fon +49-(0)2154-8162.0 - fax +49-(0)2154-8162.499  
e-mail info.miw@motracindustries.com  
internet www.motracindustries.com

**CP-130-101-00**

(subject to change)

## Ordering example:

RVPP - 10N - C - 0 - 30  
|        |        |        |        |  
**A**    **B**    **C**    **D**    **E**

## Model code:

- |   |  |
|---|--|
| <b>A</b> <b>design</b><br>relief-valve<br>poppet type valve<br>pilot operated | <b>D</b> <b>construction</b><br>0 = screw-in valve   |
| <b>B</b> <b>size and sealing</b><br>10N = Buna (NBR)<br>10V = Viton (FPM)     | <b>E</b> <b>pressure range</b><br>15 = 3.4 - 105 bar<br>30 = 3.4 - 210 bar<br>50 = 3.4 - 350 bar |
| <b>C</b> <b>adjustment</b><br>S = screw adjustment<br>C = cap<br>K = handknob |  |

## Technical Data:

<b>nominal pressure:</b>	350 bar
<b>nominal flow:</b>	95 l/min
<b>weight:</b>	0.17 kg
<b>temperature range:</b>	-40°C to 120°C
<b>fluids:</b>	hydraulic oil as per DIN 51524 T1 (ISO TC 131)
<b>max. leakage:</b>	5 drops/min at 28.5 cSt (50°C) and 90% crack pressure
<b>seals:</b>	optional Buna (NBR) or Viton (FPM), as well as Teflon wascher (PTFE)
<b>crack pressure:</b>	adjustment will be determined at a flow of 0.25 l/min
<b>cavity:</b>	C-10-2 see datasheet no. <a href="#">IK-100-109-00</a>
<b>housing:</b>	2LH-10.-B.. see datasheet no. <a href="#">IH-100-000-00</a>
<b>seal kit:</b>	SP-CDS-10N-21 (NBR), SP-CDS-10V-21 (FPM)