

shuttle valve, screw-in type

BDSV-10.-3-0

CC-320-101-00

(subject to change)

BUCHER
hydraulics

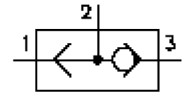

HEX 27mm
(torque
cartridge:
48 - 54 Nm)

cavity:
C-10-3
see
data-sheet no.:
[IK-300-109-00](#)

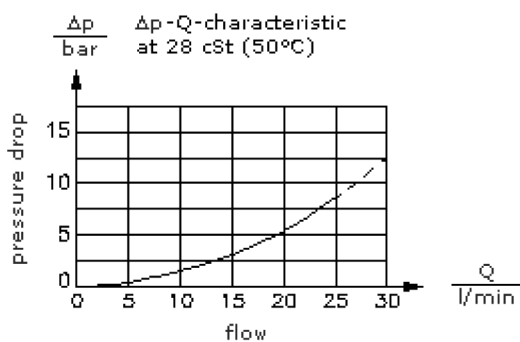
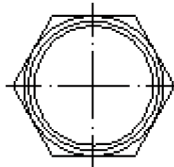
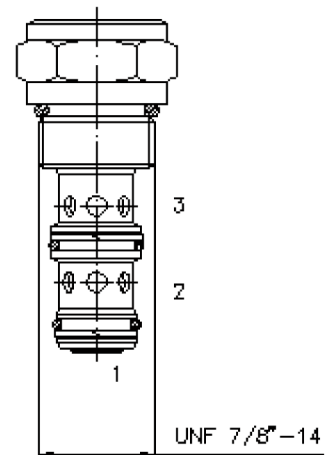
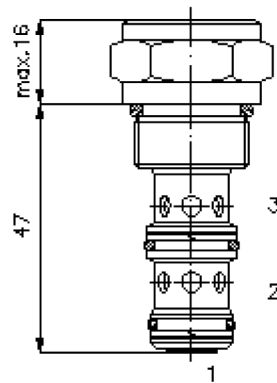

shuttle valve, screw-in type

BDSV-10.-3-0

BUCHER
hydraulics

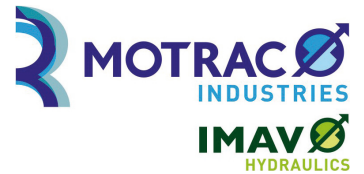

Motrac Hydraulik GmbH
Siemensring 87 - D-47877 Willich
fon +49-(0)2154-8162.0 - fax +49-(0)2154-8162.499
e-mail info.miw@motracindustries.com
internet www.motracindustries.com

CC-320-101-00

(subject to change)

Ordering example:

BDSV - 10N - 3 - 0
| | | |
A **B** **C** **D**

Model code:

- | | |
|---|--|
| A design
shuttle valve
ball type | C function mode
3-way cavity |
| B size and sealing
10N = Buna (NBR)
10V = Viton (FPM) | D construction
0 = screw-in valve |

Technical Data:

nominal pressure:	350 bar
nominal flow:	23 l/min
weight:	0.11 kg
temperature range:	-40°C to 120°C
fluids:	hydraulic oil as per DIN 51524 T1 (ISO TC 131)
max. leakage:	5 drops/min at 22 cSt (50°C) and 350 bar
seals:	optional Buna (NBR) or Viton (FPM), as well as Teflon wascher (PTFE)
cavity:	C-10-3 see datasheet no. IK-300-109-00
housing:	3LH-10.-B.. see datasheet no. IH-300-000-00
seal kit:	SP-CDS-10N-32 (NBR), SP-CDS-10V-32 (FPM)