

check valve, screw-in type (manual operated)

POCI-10.-M-0-..

CC-210-102-00

(subject to change)

BUCHER
hydraulics

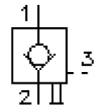

HEX 1/2"

HEX 27 mm
(torque
cartridge:
48 - 54 Nm)

cavity:
C-10-3S
see
data-sheet no.:
[IK-200-109-00](#)

Attention:
Please see note at
data-sheet no.:
[IK-200-109-00](#) !

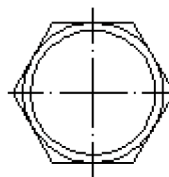
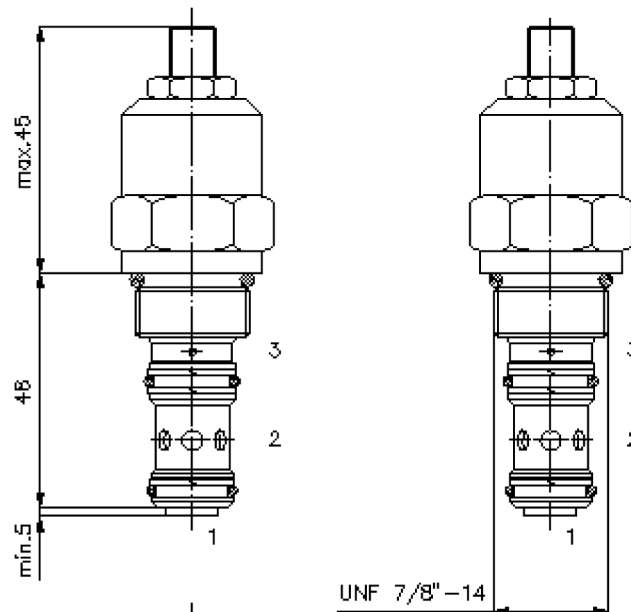

$\frac{\Delta p}{\text{bar}}$ Δp -Q-characteristic
at 28 cSt (50°C)

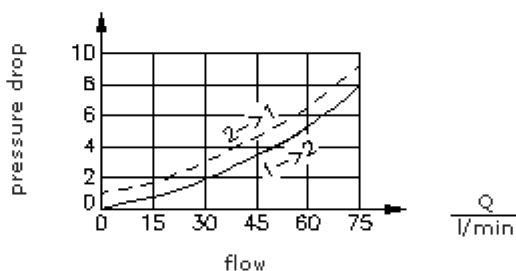

check valve, screw-in type (manual operated)

POCI-10.-M-0-..



Motrac Hydraulik GmbH
Siemensring 87 - D-47877 Willich
fon +49-(0)2154-8162.0 - fax +49-(0)2154-8162.499
e-mail info.miw@motracindustries.com
internet www.motracindustries.com

CC-210-102-00

(subject to change)

BUCHER
hydraulics

Ordering example:

POCI - 10N - M - 0 10
| | | | |
A **B** **C** **D** **E**

Model code:

- | | |
|--|--|
| A design
check valve
pilot operated by hydraulics
pilot ratio 3 : 1 | C adjustment
M = manually pilot operated |
| B size and sealing
10N = Buna (NBR)
10V = Viton (FPM) | D construction
0 = screw-in valve |
| | E design
10 = 0.7 bar
30 = 2.1 bar
60 = 4.1 bar |

Technical Data:

nominal pressure:	350 bar
nominal flow:	70 l/min
weight:	0.18 kg
temperature range:	-40°C to 120°C
fluids:	hydraulic oil as per DIN 51524 T1 (ISO TC 131)
max. leakage:	5 drops/min at 22 cSt (50°C) and 350 bar
seals:	optional Buna (NBR) or Viton (FPM), as well as Teflon wascher (PTFE)
cavity:	C-10-3S see datasheet no. IK-200-109-00
housing:	3SLH-10.-B.. see datasheet no. IH-200-000-00
seal kit:	SP-CDS-10N-33S (NBR), SP-CDS-10V-33S (FPM)